

OCTA FLOOR

CLASSIC | ECO

**DOUBLE FLOORS
WITH A SYSTEM**

DOWN

TO

EARTH

INTRO

Firmly grounded. Proven. A solid standing. We are all following the laws of gravity. No matter if we are standing, sitting or lying – there is always something beneath us. So we asked ourselves how a floor must be constructed so as to provide the best base for your exhibition booth or event. A floor that is easy to handle and flexible to use. Before, during and after installation. Here are our basic answers.



STOCK PIL ED

**THE WORLD'S LARGEST FAIR
GROUNDS ARE LOCATED IN
HANNOVER, COVERING AN
EXHIBITION AREA OF 496.000 M².**

CONTENT

OCTAFLOOR floor systems	6
OCTACLASSIC FLOOR	8
Technical features	10
Details	12
OCTAECO FLOOR	14
Technical features	16
Details	18

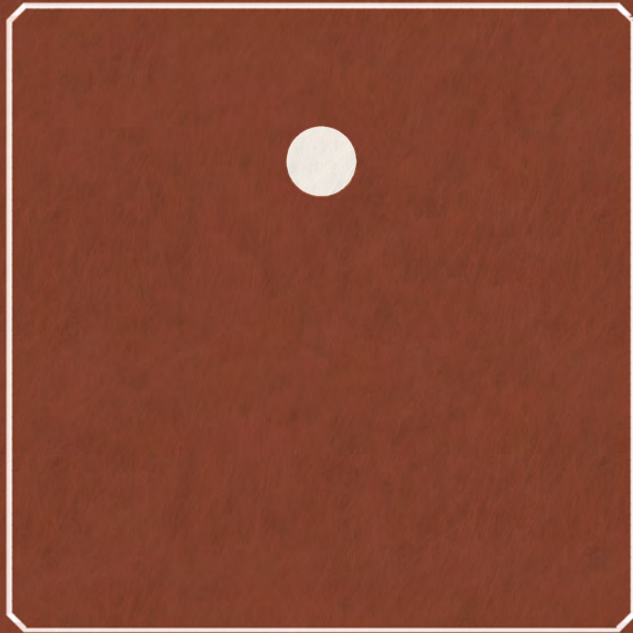

1 SUPPLIER 2 FLOORS ABSOLUTE FREEDOM

FOR YOUR PROJECT

It's the product you don't see but so many need. It's the silent hero that makes all above it function and work. Working load limits of up to 20,000 kg per square meter. Water and weatherproof. Quick and easy to install. All this makes OCTAfloor more than just double floors. They are suitable for every project of any size. Indoors and outdoors. Individually adjustable to special shapes or uneven floors. With illuminated edges and edge guards. You are looking for a system that's not only down to earth and reliable, but also sustainable? We give you a choice of two.

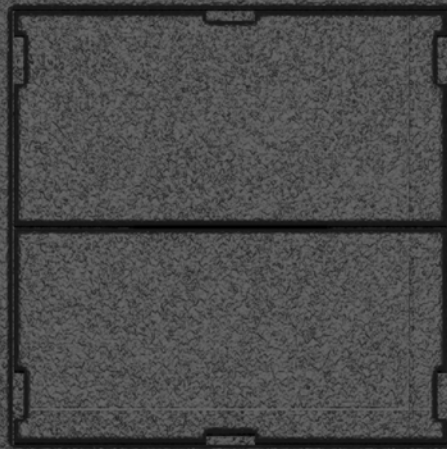
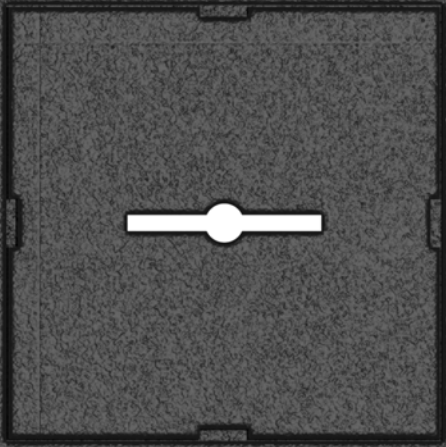



APPROVED ADJUSTABLE LIGHTWEIGHT

THE CLASSIC. MADE BY OCTANORM.

A floor system that convinces with its reliability. Proven countless times. Individually adjustable floor panels and infinitely adjustable height – OCTAclassic floor combines flexibility and stability. You are looking for a light double floor system for your indoor events? You found it.

OCTACLASSIC FLOOR



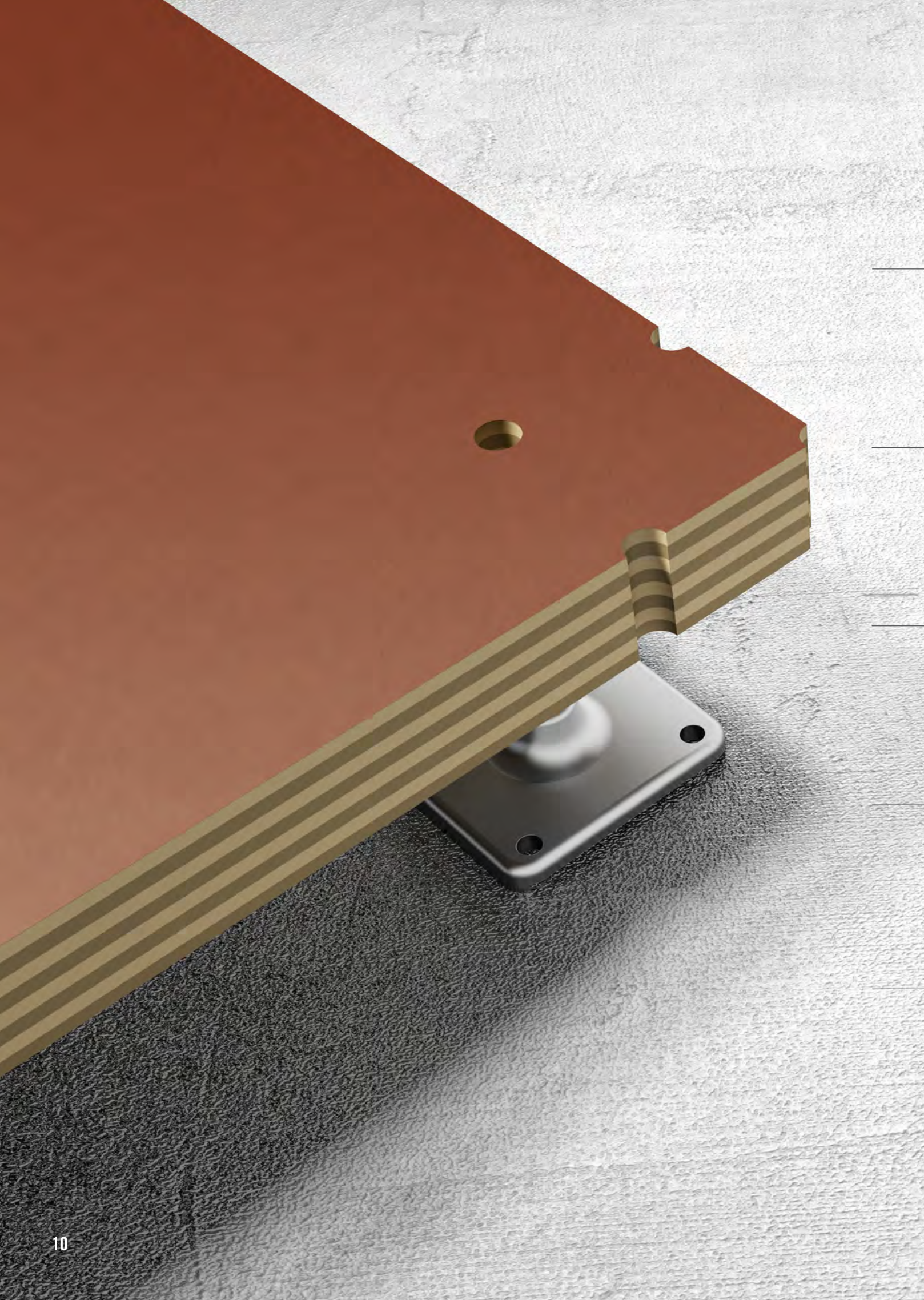

TECHNICAL FEATURES

OCTAclassic floor



working load



use

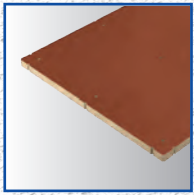

3 panel sizes

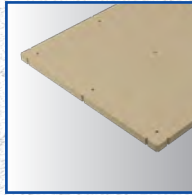

individual panel



different adjustable feet



cable outlets per m²

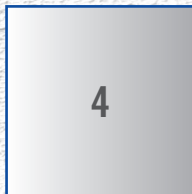

possible cable outlets per m² by rotating the panel

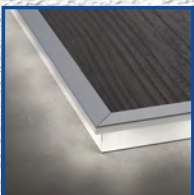

illuminated edge guards possible



25 m² of floor panels on one pallet

High working loads. Child's play.

The working load limit can be adjusted individually through the amount of feet installed. Depending on your requirements, 4 up to 9 feet can be installed to maximize the loading capacity.

3 panel sizes. Countless possibilities.

The standard sizes of our floor panels are 998 × 998 mm, 998 × 498, and 498 × 498 mm. But since the SP12 tile can be cut to size individually, this does not limit your freedom in the slightest.

Stairs. Infinitely.

The system offers three different feet, two of which are infinitely variable: allowing for heights of 95 – 225 mm (including tile height).

Light weight. Easy handling.

The OCTAclassic floor is the light weight of our floor systems. It scores not just because of the infinitely adjustable height, but also because of the low weight. This allows for large platforms being moved even with small equipment.



The working load limit is increased with the amount of feet.

The working load limit of a single panel can be adjusted individually to the requirements. You can increase your working load limit from 750 to 5,000 kg/m².

DETAILS

OCTAclassic floor

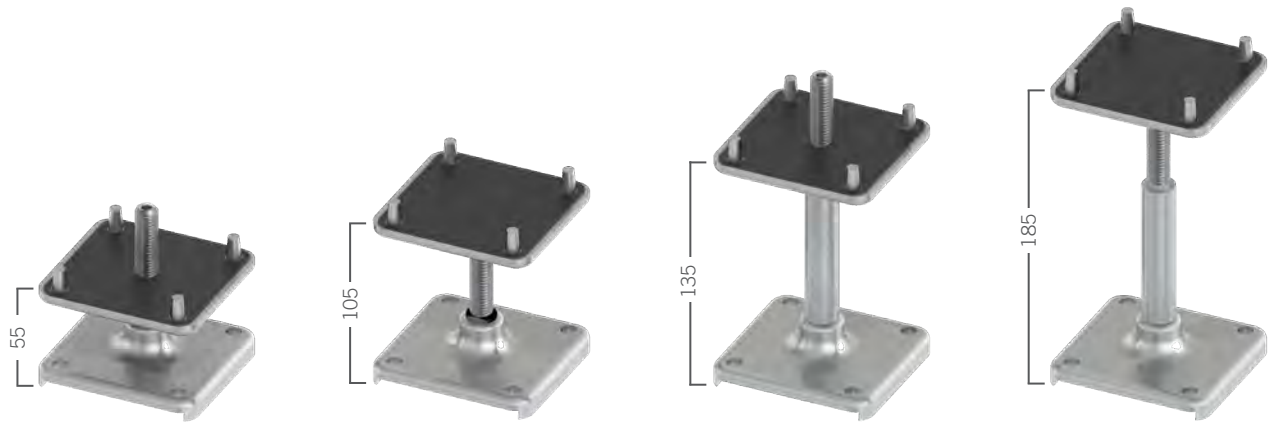

2 adjustable feet. Infinitely adjustable height.

By combining the different feet, different infinitely adjustable landing heights are possible. Noise suppressors and anti-slip rubber plates ensure safety and provide unwanted footfall sound insulation.

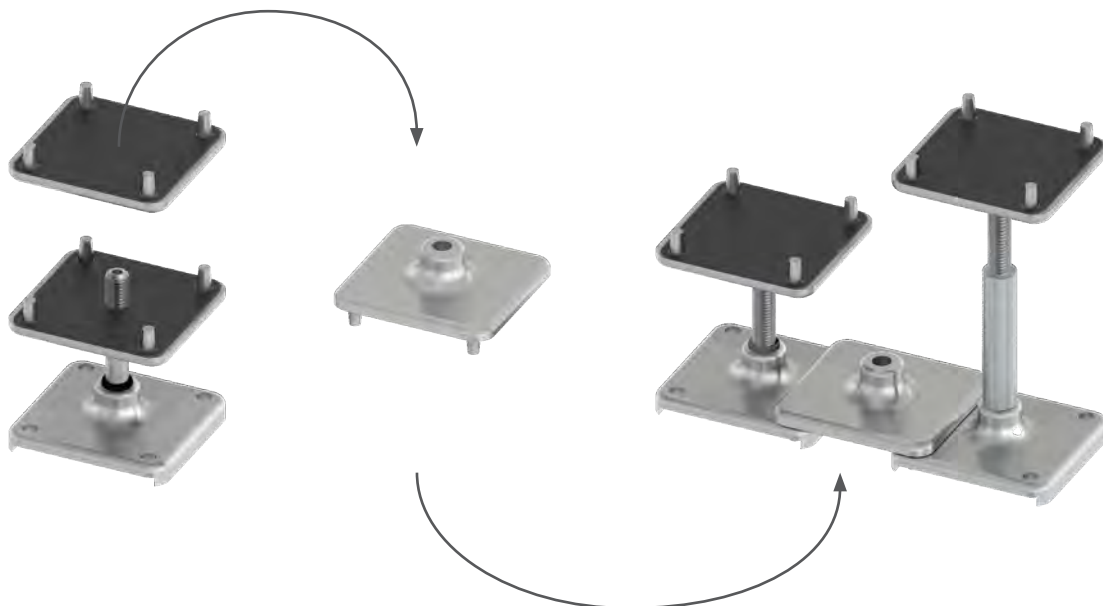



QUICK EXTREMELY FLAT HEAVY DUTY

BIG IMPACT IN LITTLE TIME

Big areas, but little time? With OCTAeco floor you can realize big, heavy-duty areas in no time. Weights of up to 20,000 kg/m² are no problem. In any weather, since the event and exhibition floor is suitable for outside use. Save time and personnel. Be it cars or heavy machinery, the OCTAeco floor is always the right foundation. Again and again.

OCTAECO FLOOR



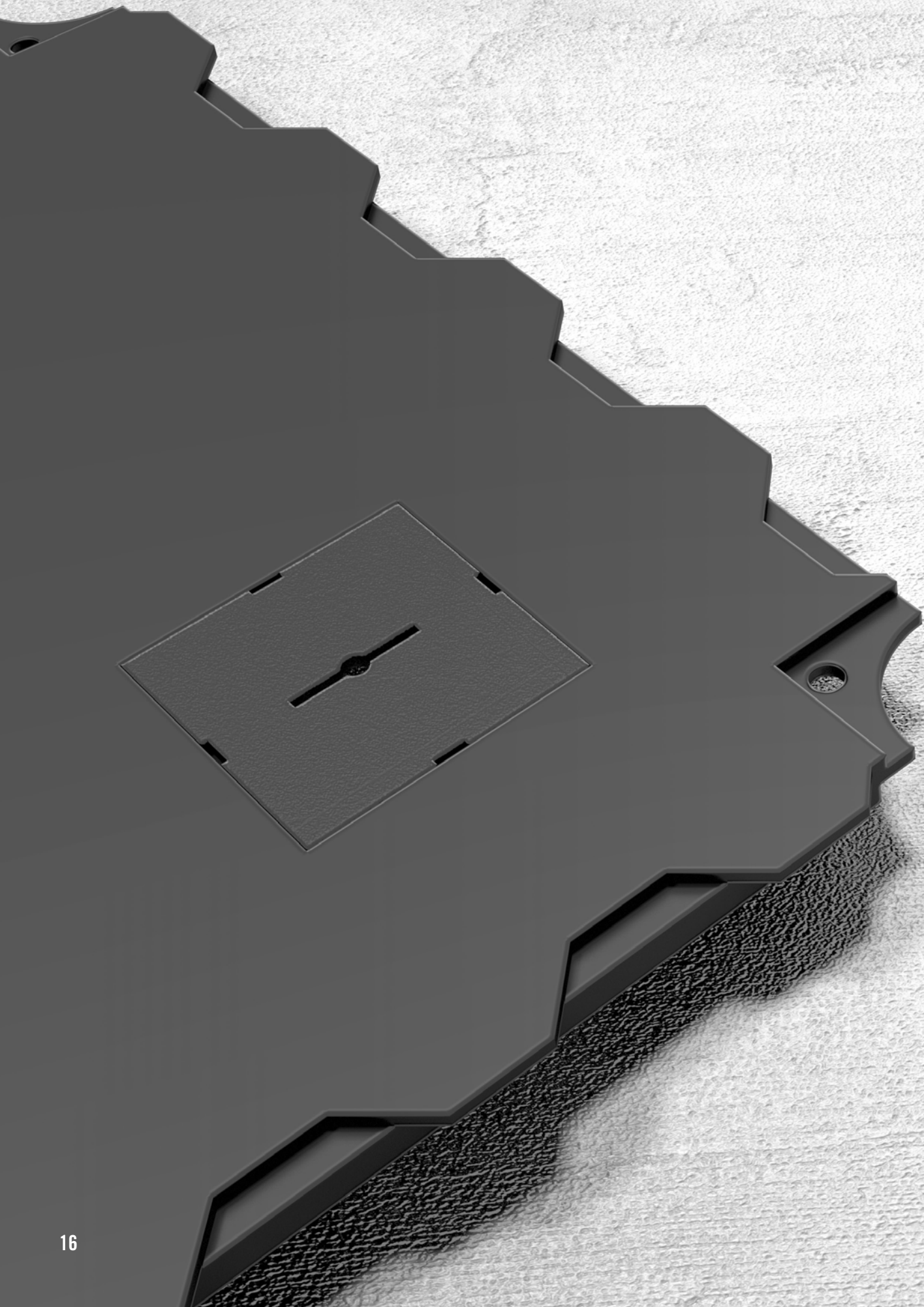

TECHNICAL FEATURES

OCTAeco floor

up to
20,000
kg/m²

working load

indoor
outdoor

use

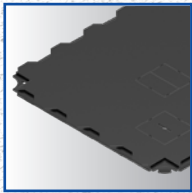

1 panel size

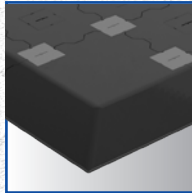

slope edge elements

9

cable outlets per m²

25

possible cable outlets
per m² by rotating the
panel

100 %
recycled
material

sustainability

Cfl-s1

flame retardant



stackable height
adaptors



25 m² of floor panels
on one pallet

Large areas. Little time.

The OCTAeco floor's biggest advantage is the fast installation. Big areas – effortless.

For heavy weights of up to 20,000 kg/m².

The well thought-out design offers maximum stability, making the floor perfect for high loads. You can even drive on it. The material is nonsensitive to moisture and thermal fluctuation.

Effortless assembly. Thanks to a simple connecting system.

The low weight in combination with the smart connector system allows for a quick and easy installation of your floor. Even with little personnel.

Individuality. With a system.

The panels can be turned 360°, allowing for a maximum of 25 possible cable outlets per m². And if you need individually adjusted special panel shapes, OCTAeco floor also offers a panel that can be cut to size. Thanks to the stackable adaptors, the raised floor system is also flexible in terms of height and barrier-free thanks to ramps – no more steps or trip hazards.

The fastest among them all.

Made from 100 % recycled plastic, OCTAeco floor has a lifetime of at least 10 years. The longevity in combination with the outstanding value for money result in a quick amortization of the system. Also, it is sustainable and flame retardant (Cfl-s1). And all this at a working load limit of up to 20 t/m². So no worries driving your 7.5 t truck onto the freshly laid floor in the future.

**ON INCINERATION,
POLYPROPYLENE BREAKS
DOWN COMPLETELY INTO
WATER AND CO₂.**

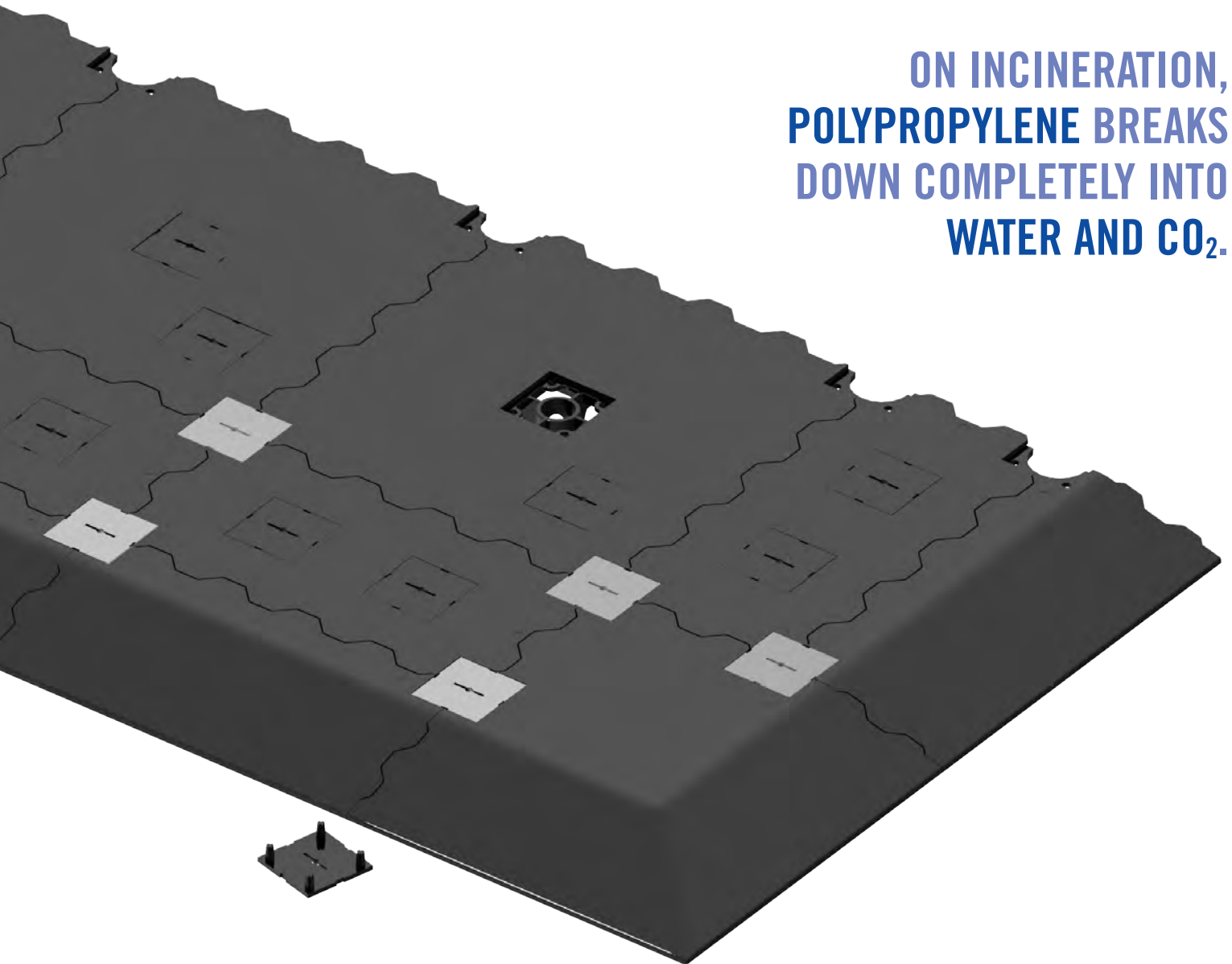

Barrier-free for more visitors.

Ramp elements make the stand accessible for all groups of visitors. They connect seamlessly to the floor panels. Which means: no tripping hazards, no ledges or edges! Perfectly fitting aluminium strips ensure a neat laminate or carpet installation.

DETAILS

OCTAeco floor

Intelligent transportation. Quick installation.

You can transport up to 25 m² of floor panels on one pallet, keeping transportation easy. Just connect four panels to each other and stack them. Thanks to the low weight, those four-packs can be laid in one step. Saving valuable time. (Ramp elements are also available as a set)



Easy cable and wire laying? Already integrated.

Up to three stacked adapters allow for a maximum overall height of 214 mm (floor panel + 1 height adaptor = 100 mm), while the bracings in the floor panels ensure a firm and secure hold. All required cables and pipes (max. Ø 54 mm) can be laid invisibly in the resulting space and positioned through the cable outlets – a quick installation without the need for additional modifications. Skirting boards are attached just as easily. Distance pieces guarantee an even distance to the floor panels.



THE 2 FLOOR SYSTEMS AT A GLANCE

	OCTACLASSIC FLOOR	OCTAECO FLOOR
		
WORKING LOAD LIMIT	up to 5,000 kg/m ²	up to 20,000 kg/m ²
MATERIAL	wood	polypropylene Cfl S1
WATER AND WEATHERPROOF	no (only indoor)	yes (outdoor)
MINIMUM TOP EDGE	95 mm	43 mm
MAXIMUM TOP EDGE	225 mm (foot + panel)	214 mm (3 adaptor + panel)
GROUND CLEARANCE	min. 55 mm	max. 28 mm
ADJUSTABLE HEIGHT	infinitely	57 mm steps
CABLE OUTLETS / M²	1	9
POSSIBLE CABLE OUTLETS PER M² BY ROTATING	4	25
WEIGHT / M²	approx. 10 kg	approx. 11 kg
PLATES CAN BE REMOVED SUBSEQUENTLY	yes	only the service plate
ASSEMBLY TIME	40 m ² / 3 persons / 15 min	40 m ² / 3 persons / 8 min
SUSTAINABILITY	often reusable	often reusable, 100% recyclable

OVERVIEW

OCTAfloor systems

Advantages over traditional chipboard flooring:

- floor pays off after just a few use
- sustainability – no waste due to repeated usage
- shortest set-up times thanks to system design
- easy assembly and reduced staff requirement
- simple laying of cables through cable outlets and ground clearance



EXHIBITION SYSTEMS
PROJECT SOLUTIONS
PRESENTATION
INTERIOR DESIGN
CLEANROOM SYSTEMS



**OCTANORM® Germany
Head Office**

Raiffeisenstraße 39
70794 Filderstadt
T. +49 711 77003-0
F. +49 711 77003-53
info@octanorm.de
www.octanorm.com

EUROPE

OCTANORM® Nordic
T. +46 8 621 6500
www.octanorm.se

OCTANORM® Polska
T. +48 22 773 0350
www.octanorm.pl

OCTANORM® Belgium
T. +32 475 35 60 76
www.octanorm.be

OCTANORM® France
T. +33 6 79 11 32 05
www.octanorm.fr

OCTANORM® UK
T. +44 20 85 45 2945
www.octanorm.co.uk

OCTANORM® Espana
T. +34 930 019 424
www.octanorm.es

OCTANORM® Hellas
T. +30 2310 79 6521
www.octanorm.gr

OCTANORM® Italia
T. +39 031 2269715
www.octsystem.it

OCTANORM® Adria
T. +386 590 56301
www.octanormadria.com

AFRICA

OCTANORM® South Africa
T. +27 11 433 2010
www.octanorm.co.za

AMERICA

OCTANORM® North America
T. +1 770 7 32 1520
www.octanormna.com

OCTANORM® México
T. +52 55 5804 6325
www.octanorm.com.mx

ASIA

OCTANORM® China
T. +86 512 6283 3336
www.octanorm.cn

OCTANORM® Japan
T. +81 45 511 8144
www.octanorm.co.jp

AUSTRALIA

OCTANORM® Australia
T. +61 3 7017 2753
www.octanorm.com.au

MIDDLE EAST

OCTANORM® Emirates
T. +971 4 340 6888
www.octanormemirates.net